



POWER TO PERFORM

PRODUCT CATALOG
COLUMBUS MCKINNON CORPORATION
ENTERTAINMENT PRODUCTS





Columbus McKinnon Entertainment Technology (CM-ET), the industry leader in providing quality lifting and positioning equipment for riggers around the globe, presents the new Lodestar Electric Chain Hoist. Generations of users have relied on the Lodestar “Motor” for consistent operation and long-life for years, and now exciting new features have been added to widen the appeal of the Lodestar to the next generation of rigging professionals.

In addition to a product line recognized in venues throughout the world, CM-ET has established a network of distributors that provide the highest level of customer service to users in the industry. Wherever the show takes place, a knowledgeable CM-ET distributor is available to offer assistance with parts, service, or accessories.

When searching for products or services to ensure that your event shines, turn to the company with more than 135 years of experience in meeting the needs of our customers – Columbus McKinnon.

TABLE OF CONTENTS

Lodestar	2
Lodestar D8+	6
Lodestar BGV-C1	7
ShowPro	8
Prostar	9
Manual Hoists	10
Trolleys & Clamps	12
Rigging & Accessories	14
Winches	18





the
to
out
com
w
for
on

LODESTAR®

Specs

CAPACITIES

1/8 to 2 TON

LIFT

60 feet standard
(other lifts available)

SPEEDS

5 to 100 feet/min

VOLTAGES

1-phase
& 3-phase available

NEW FEATURES ON THIS NEXT GENERATION OF LODESTAR

5 POCKET LIFTWHEEL
IMPROVED CHAIN WEAR & SMOOTH LIFTING

CLUTCH OUTSIDE GEAR TRAIN
MEETS INTERNATIONAL STANDARDS

PRECISION HELICAL GEARING
FOR QUIETER OPERATION

REDESIGNED CONTROL PANEL
FOR EASIER ACCESS

STANDARD FEATURES

HEAVY DUTY DC BRAKE

Designed for a long service life, the brake location allows for quick access & easy inspection.

LOW VOLTAGE CONTROL

110 Volt for long cable runs without voltage drop. 24 & 48 Volt optional. (Low Voltage Unit Only)

DURABLE & LIGHTWEIGHT HOUSING

Cast aluminum. Black powder coated finish for low visibility.

GEARING

Helical design for long wear life and smooth operation.

LOAD CHAIN

Designed and manufactured by Columbus McKinnon. Zinc plated to protect against corrosion. Optional black finish available.

DUTY CYCLE

H-4 duty rated for heavy duty application. 2M+ FEM class. 50% Duty Cycle or 300 on/off per hour.

ELECTRICAL

Finger safe wiring meets all electrical codes. Quick change plugs allow for voltages 208 through 460. Prevents improper voltage connections which can cause hoist damage. (Low Voltage Unit Only)

ADJUSTABLE LIMIT SWITCH

Adjustable screw limit switch that will automatically stop the hook at any predetermined point when either lifting or lowering, preventing overtravel. (Low Voltage Unit Only)

OVERLOAD PROTECTOR

Designed to prevent lifting of excessive overloads. Helps prevent lifting of dangerous overloads.

METRIC RATED

MEETS REQUIREMENTS

Meets or exceeds world standards.

ROAD READY

Easy to stow and travel.

LIFETIME WARRANTY

The industry's best.

OPTIONAL FEATURES

DOUBLE DC BRAKE

Two independent acting DC brakes for redundant braking. Field installation kit available.

AC ELECTRIC BRAKE

ENCODERS AVAILABLE

Incremental & Absolute.

CHAIN BAGS

Cloth type bags easy-to-mount.

VARIABLE SPEED UNITS AVAILABLE

ALLOY LATCHLOK HOOKS

Remains locked until released by the operator, even if chain goes slack.

DIRECT CONTROL UNIT OPTION

The CM Lodestar is available as a Direct Control Unit. Featuring a single cable, this Direct Control Unit can be used as part of a system with multiple units with a single control. The Lodestar is compatible with most Direct Control Motor Controllers.



CM

LODESTAR®

CM

LODESTAR®

The POWER to
PERFORM

LODESTAR

Specifications, Dimensions & Key Components

DIMENSIONS

DRAWING LEGEND	LODESTAR MODELS		
	B, C, F	J, JJ, L, LL	R, RR
A	16.20"	18.5625"	24.125"
B	6.08"	7.62"	7.62"
C	.67"	.875"	1.125"
D	11.80"	10.03"	10.03"
F	8.94"	13.01"	13.01"
H	1"	1.1875"	1.5"
I	4.46"	6.93"	5.57"
J	4.22"	5.69"	7.05"
M	1"	1.125"	1.3125"
P	6.62"	8.22"	8.22"

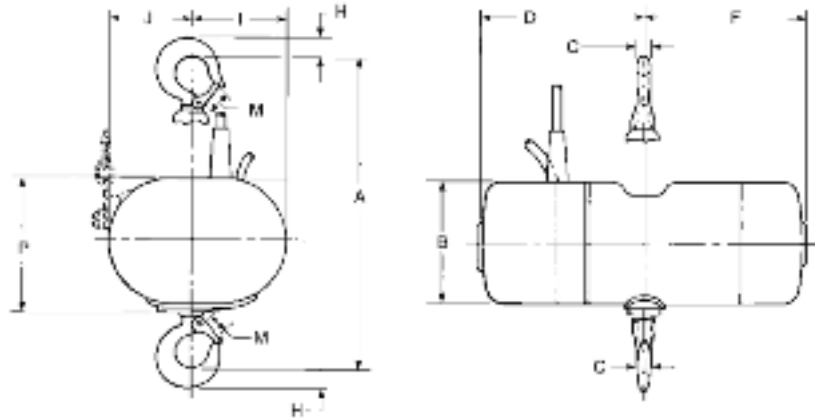

SPECIFICATIONS D8

MODEL	RATED LOAD TON*	LIFTING SPEED (FPM)	MOTOR HP	OPERATING VOLTAGE**	FULL LOAD AMPS	WORK RATING		REEVING	PROTECTION CLASS	NOISE LEVEL	LIFT (FEET)***
						HMI	FEM				
B	1/4	16	1/4	230/460-3-60	1.8/1.1	H4	2M+	1	IP54	73 dB	60
C	1/4	32	1/2	230/460-3-60	2.2/1.3	H4	2M+	1	IP54	73 dB	60
F	1/2	16	1/2	230/460-3-60	2.2/1.3	H4	2M+	1	IP54	73 dB	60
J	1/2	32	1	230/460-3-60	3.7/2.2	H4	2M+	1	IP54	73 dB	60
JJ	1/2	64	2	230/460-3-60	7.9/5.0	H4	2M+	1	IP54	73 dB	60
L	1	16	1	230/460-3-60	3.7/2.2	H4	2M+	1	IP54	73 dB	60
LL	1	32	2	230/460-3-60	7.9/5.0	H4	2M+	1	IP54	73 dB	60
R	2	8	1	230/460-3-60	3.7/2.2	H4	2M+	2	IP54	73 dB	60
RR	2	16	2	230/460-3-60	7.9/5.0	H4	2M+	2	IP54	73 dB	60

* Metric Tons
 ** Single Phase Models available
 *** Lifts other than 60ft available (Standard Units shipped less chain unless specified)
 Consult factory for additional speeds and capacities



LOAD CHAIN

Sizes available from 1/4 in. to 5/16 in.
 Meets or exceeds many national and international standards. Zinc plated supplied as standard.
 Black phosphate finish available. 100% proof tested.

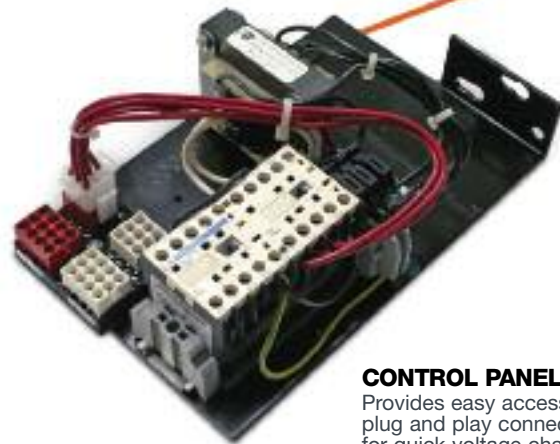

CONTROL PANEL

Provides easy access to controls, plug and play connectors allow for quick voltage change for dual voltage motors. Fuses located on terminal strip (optional).



LIFT WHEEL

5 Pocket Liftwheel increases chain and liftwheel engagement while providing smoother lifting, less vibration and reduced chain wear when properly maintained.



BRAKE

Heavy Duty DC Brake is standard. AC Brake and Double DC Brake are also available.



LIMIT SWITCH

Adjustable screw limit switch that will automatically stop the hook at any predetermined point when either hoisting or lifting.

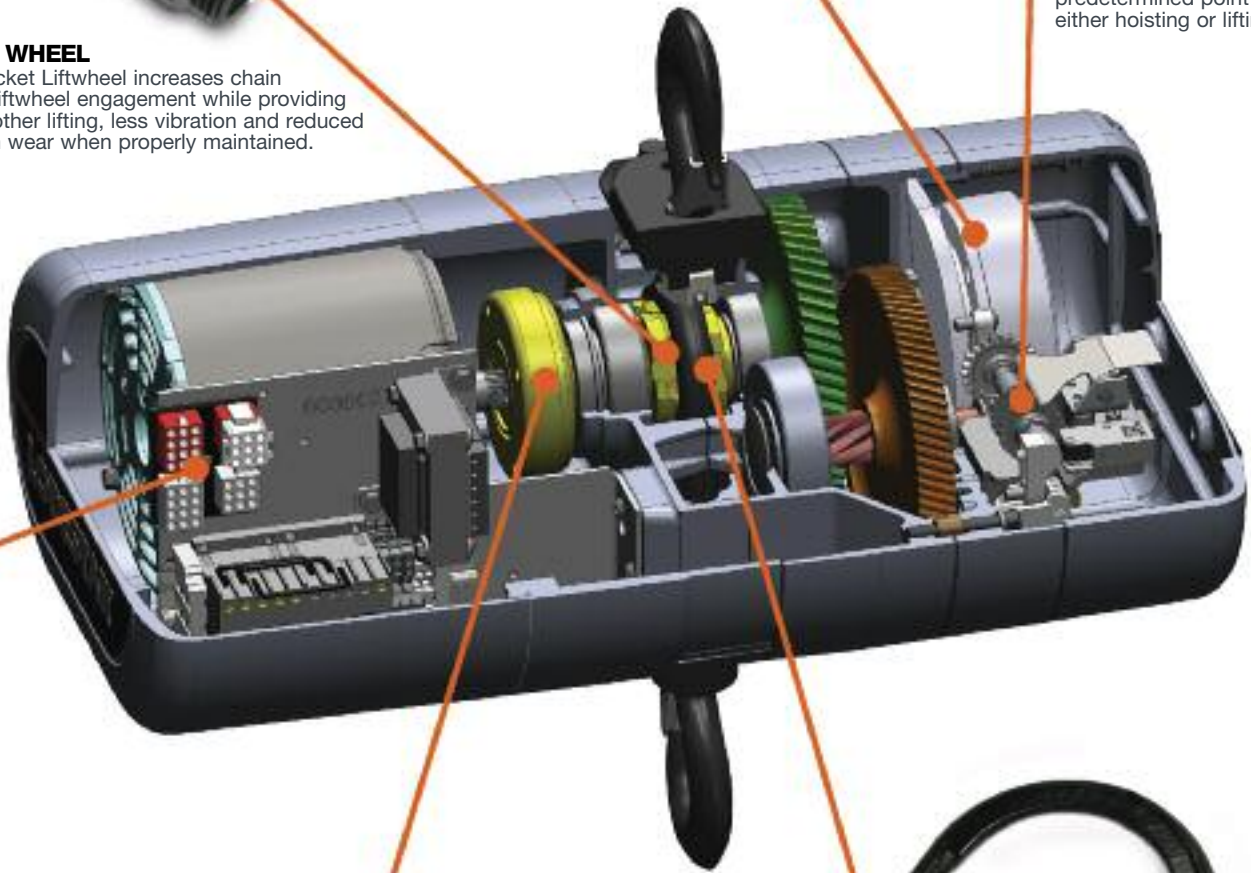

CLUTCH

Designed to prevent lifting of excessive overloads. Located outside the gear box. Adjustable and easy to access.



INTERNAL CHAIN GUIDE

Stamped Steel guide coated for corrosion resistance and quiet operation, while keeping the load chain and liftwheel aligned.



LODESTAR[®]

ELECTRIC CHAIN MOTOR

2-TON, SINGLE-REEVED

The CM[®] entertainment Lodestar[®] is now available as an economical 2-ton, single-reeved unit that's ideal for a variety of lifting applications. And, because it's a single-reeved unit, overall weight is decreased making it easier to transport and rig compared to a traditional double-reeved unit.

BENEFITS & FEATURES

LESS MAINTENANCE & EASIER INSPECTION

- Brake location allows for quick access and easy inspection.
- Lifetime grease-lubricated Gear Box means no oil change is required.
- Clutch located outside the Gear Box allows for easy access which eliminates the need for complete disassembly and reduces downtime.

IMPROVED SERVICEABILITY

Easy access to the Clutch, Motor, Electrical Control Panel and Brake Assembly.

LONGER SERVICE LIFE

- Heavy-duty DC brake is designed for a long service life.
- Lifetime grease-lubricated Gear Box and helical gearing ensures better wear and smooth operation. Heavy-duty rated motors.

IMPROVED LOAD SAFETY

Clutch is located outside the load path preventing slipping of the load in an overload condition when the brake is not powered.

IMPROVED CHAIN LIFE

5-Pocket Lift Wheel provides better chain and lift wheel engagement for smoother lifting and reduced vibration equating to less wear and a longer chain life. Zinc plating protects chain from environmental conditions.

EASY ACCESS CONTROL PANEL

Finger-safe wiring and plug-and-play connectors on the Control Panel allow for quick voltage change, easy access to terminal strips and simple fuse installation.

ZINC PLATED LOAD CHAIN

Designed and manufactured in the USA by Columbus McKinnon. 10 millimeter, zinc plated Star Grade load chain protects against corrosion.

ADJUSTABLE LIMIT SWITCH

Easy-to-adjust screw limit switch automatically stops the hook at any predetermined point when either lifting or lowering, preventing overtravel.

OVERLOAD PROTECTOR

Helps prevent lifting of dangerous overloads.

METRIC RATED

LIFETIME WARRANTY

The industry's best warranty against manufacturing and material defects.

STANDARD ROTATABLE LIMIT SWITCH

Designed for quick reset of limit position.

SWIVEL OR RIGID HOOK SUSPENSION AVAILABLE

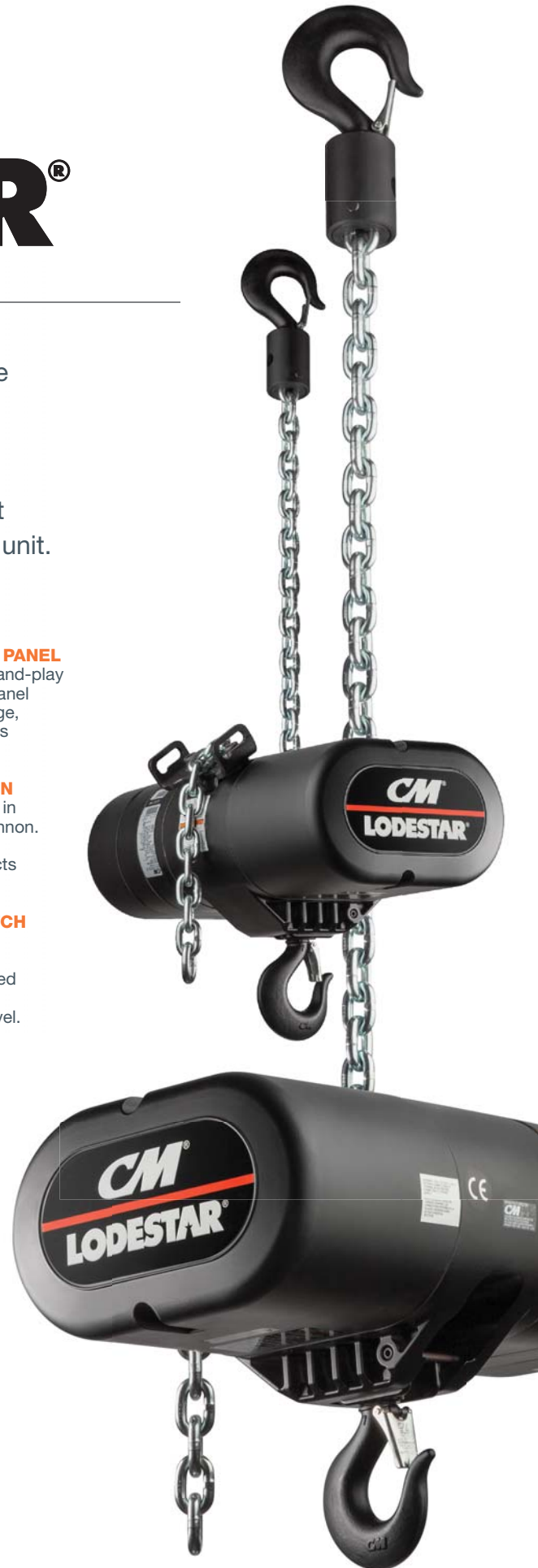



LODESTAR[®]

ELECTRIC CHAIN MOTOR

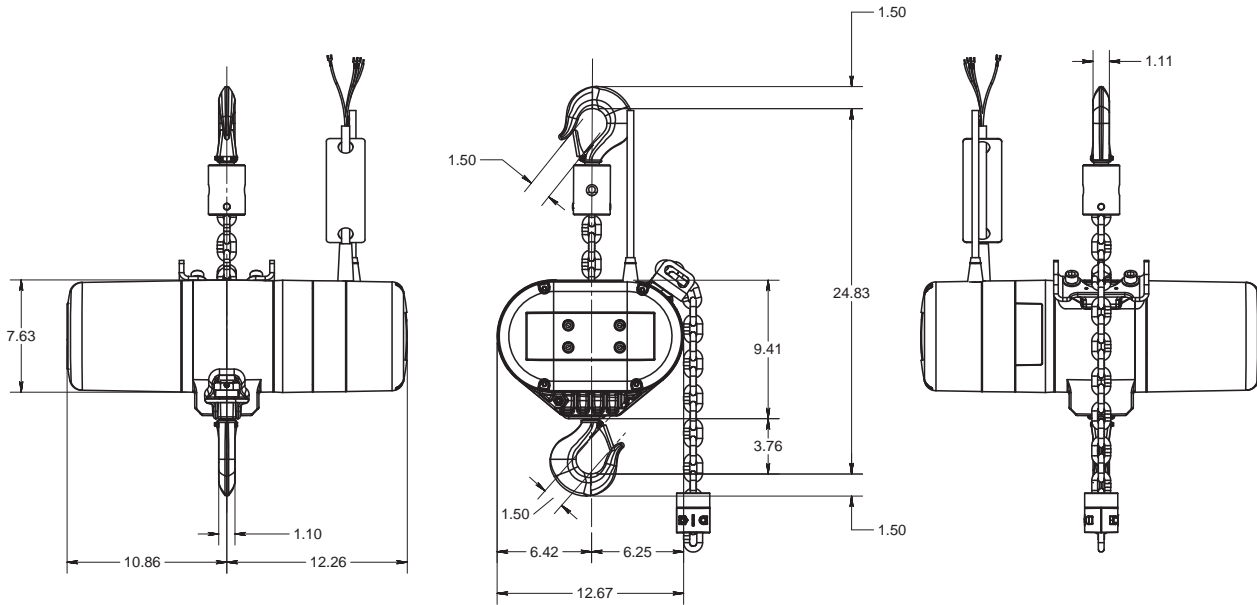

Dimensions (in inches) are RRS model CM-ET Lodestar 2 Ton Single Reeved with Swivel Latch Type Hook Suspension.

OPTIONAL FEATURES

DIRECT CONTROL

Direct Control allows multiple motor units to be operated with a single control.

D8+

Meets all Standard VPLT SR 2.0/SQP2 requirements.

BGV-C1

Meets all standard C1 and DIN 56950 requirements.

VARIABLE SPEED DRIVE (VFD)

DOUBLE DC BRAKE

Two independent acting DC Brakes for redundant braking. Field installation kit available.

PRIMARY & SECONDARY TRANSFORMER FUSING



USA: 800.888.0985 • 716.689.5400 • Fax: 716.689.5644
CDN: 877.264.6478 • Fax: 877.264.6477
www.cm-et.com

LODESTAR D8+

CAPACITIES
70 to 1500 KG

LIFT
60 feet standard

SPEEDS
5 to 64 feet/minute

VOLTAGES
3-phase available

The Lodestar D8+ meets all Standard SR2.0 requirements. It's clutch, outside the load path, acts as a precise overload device; and design factor is 10:1 with a double brake installed. The Lodestar D8+ is in accordance with the VPLT Code of Practice.

KEY FEATURES

ELECTRO-MECHANICAL DOUBLE BRAKES

5 POCKET LIFT WHEEL
For quiet & smooth operation.

68 dB OPERATIONAL NOISE
A result of the Double Brake System.

GEARING
Precision machined gears heat treated for strength and durability.

INTERNAL CHAIN GUIDE
PVC black coated for quieter operation.

LOW VOLTAGE CONTROL
110 Volt for long cable runs without voltage drop. 24 & 48 Volt optional.

DUTY CYCLE
H-4 duty rated for heavy duty application. 2M+ FEM class. 50% Duty Cycle or 300 on/off per hour.

10:1 MECHANICAL DESIGN FACTOR

STANDARD FEATURES

OVERLOAD PROTECTION
Rated operational range between 125 and 150/160%. Clutch is outside the load path when disconnected from power.

DURABLE & LIGHTWEIGHT HOUSING
Cast aluminum. Black powder coated finish for low visibility.

METRIC RATED

LOAD CHAIN
Designed and manufactured by Columbus McKinnon. Zinc plated to protect against corrosion. Black phosphate finish optional.

THE INDUSTRY'S BEST LIFETIME WARRANTY

MEETS OR EXCEEDS WORLD STANDARDS
Meets German Code of Practice VPLT SR2.0

OPTIONAL FEATURES

CHAIN BAG
Easy-to-Mount Cloth Type Bags.

CHAIN STOP
Mounted on load chain to prevent overtravel. Standard on Direct Control.



SPECIFICATIONS D8+

MODEL	RATED LOAD (KG)	LIFTING SPEED (FPM)	MOTOR HP	OPERATING VOLTAGE	FULL LOAD AMPS	WORK RATING HMI	FEM	REEVING	PROTECTION CLASS	NOISE LEVEL	LIFT (FEET)
B	125	16	1/4	230/460-3-60	1.8/1.1	H4	2M+	1	IP54	68 dB	60
C	125	32	1/2	230/460-3-60	2.2/1.3	H4	2M+	1	IP54	68 dB	60
F	250	16	1/2	230/460-3-60	2.2/1.3	H4	2M+	1	IP54	68 dB	60
J	250	32	1	230/460-3-60	3.7/2.2	H4	2M+	1	IP54	68 dB	60
JJ	500	64	2	230/460-3-60	7.9/5.0	H4	2M+	1	IP54	68 dB	60
L	650	16	1	230/460-3-60	3.7/2.2	H4	2M+	1	IP54	68 dB	60
LL	500	32	2	230/460-3-60	7.9/5.0	H4	2M+	1	IP54	68 dB	60
R	1300	8	1	230/460-3-60	3.7/2.2	H4	2M+	2	IP54	68 dB	60
RR	1000	16	2	230/460-3-60	7.9/5.0	H4	2M+	2	IP54	68 dB	60
RT	1500	5	1	230/460-3-60	3.7/2.2	H4	2M+	3	IP54	68 dB	60

* Lifts other than 60ft available (Standard Units shipped less chain unless specified)

See dimensions for Lodestar D8+ on Page 4

BGV-C1 SERIES

CAPACITIES
250 to 1300 KG

LIFT
60 feet standard

SPEEDS
16 to 100 feet/minute

VOLTAGES
3-phase available

The Lodestar BGV-C1 Series meets the BGV-C1 German regulation for entertainment rigging. Available with fixed or variable speed, the Lodestar BGV-C1 can be adapted to reach a System Integrity Level 3 (SIL3)*.

KEY FEATURES

ELECTRO-MECHANICAL DOUBLE BRAKES

5 POCKET LIFT WHEEL

For quiet & smooth operation.

68 dB OPERATIONAL NOISE

A result of the Double Brake System.

GEARING

Precision machined gears heat treated for strength and durability.

INTERNAL CHAIN GUIDE

PVC black coated for quieter operation.

LOW VOLTAGE CONTROL

110 Volt for long cable runs without voltage drop. 24 & 48 Volt optional.

DUTY CYCLE

H-4 duty rated for heavy duty application. 2M+ FEM class. 50% Duty Cycle or 300 on/off per hour.

10:1 MECHANICAL DESIGN FACTOR

UNDERLOAD PROTECTION

With load cell installed.

MODULAR MULTI-PIN CONNECTOR

With multi-wire shielded cable.

4 POSITION LIMIT SWITCH

With active spring micro-switch.

BUILT-IN PLC

For safety function monitoring, Brake and Limit Switch integrity, Load Cell reading, Overload and Underload settings.

STANDARD FEATURES

OVERLOAD PROTECTION

Rated operational range between 125 and 150/160%. Clutch is outside the load path when disconnected from power.

DURABLE & LIGHTWEIGHT HOUSING

Cast aluminum. Black powder coated finish for low visibility.

METRIC RATED

LOAD CHAIN

Designed and manufactured by Columbus McKinnon. Zinc plated to protect against corrosion. Black phosphate finish optional.

THE INDUSTRY'S BEST LIFETIME WARRANTY

MEETS OR EXCEEDS WORLD STANDARDS

Meets German Regulation BGV-C1.

OPTIONAL FEATURES

CHAIN BAG

Easy-to-Mount Cloth Type Bags.

CHAIN STOP

Mounted on load chain to prevent overtravel.

LOAD CELL

Built in on the suspension hook.

* SIL3 requires a BGV-C1 SIL3 certified controller not included.



SPECIFICATIONS BGV-C1

MODEL	RATED LOAD (KG)	LIFTING SPEED (FPM)	MOTOR HP	OPERATING VOLTAGE	FULL LOAD AMPS	REEVING	PROTECTION CLASS	NOISE LEVEL	LIFT (FEET)
F	250	16	1/2	230/460-3-60	2.2/1.3	1	IP54	68 dB	60
J	250	32	1	230/460-3-60	3.7/2.2	1	IP54	68 dB	60
JJ	500	64	2	230/460-3-60	7.9/5.0	1	IP54	68 dB	60
L	650	16	1	230/460-3-60	3.7/2.2	1	IP54	68 dB	60
LL	500	32	2	230/460-3-60	7.9/5.0	1	IP54	68 dB	60
RR	1000	16	2	230/460-3-60	7.9/5.0	2	IP54	68 dB	60
VARISTAR	500	100	3 1/2	230/460-3-60	10.4/6.2	1	IP54	68 dB	60

* Lifts other than 60ft available (Standard Units shipped less chain unless specified)

See dimensions for BGV-C1 on Page 4

SHOWPRO

CAPACITIES

1/2, 1 & 2 Tonne
500, 1000 & 2000 Kgs.

LIFT

66 feet
20 meters

SPEEDS

16 feet/minute at 60Hz
4.1 meters/minute at 50Hz

The ShowPro electric chain hoist is designed to meet all basic entertainment rigging needs. Low Voltage Control and Direct Control available. Direct Control hoists offer an optional control cable fitted with IEC style connectors, 4-way hoist controller and chain bag for a complete plug and play system.

KEY FEATURES

VERSATILE

Operates on a wide range of 3-phase voltages.

LIGHTWEIGHT

Aluminum housing.

EFFICIENT

Engineered for smooth, quiet operation; featuring a 5-pocket lift wheel.

RELIABLE

Overload clutch protects hoist, operator, structure from damaging overloads.

LIFETIME WARRANTY

Against defective materials and workmanship.



SPECIFICATIONS SHOWPRO

MODEL	CAPACITY (TONNE)	NUMBER OF CHAINS	LIFT (FEET)	LIFTING SPEED (FPM)	MOTOR H.P.	MOTOR VOLTAGE/ PHASE/ HERTZ	AMPS	MOTOR VOLTAGE/ PHASE/ HERTZ	AMPS	APX. SHIP WT. W/ 66 FT. LIFT (LBS)
SP1003	1/2	1	66	16	1/2	230/3/60	2	460/3/60	1	119
SP2003	1	1	66	16	1	230/3/60	3.2	460/3/60	1.6	126
SP4003	2	2	66	8	1	230/3/60	3.2	460/3/60	1.6	186

Standard operational 3-phase voltages — 208, 230, 380, 415, 460 @ 50 or 60 Hertz

DIMENSIONS

MODEL	CAPACITY		CHAIN SIZE		HOUSING DIMENSIONS (IN.)		
	(TONNE)	(KG.)	(IN.)	(mm)	H	W	L
SP1003	1/2	500	9/32	7.1	8 11/16	8 11/16	24 3/8
SP2003	1	1000	9/32	7.1	8 11/16	8 11/16	24 3/8
SP4003	2	2000	9/32	7.1	8 11/16	8 11/16	24 3/8

PROSTAR

CAPACITIES
300 to 1000 LBS

LIFT
60 feet standard

SPEEDS
8 to 40 feet/minute

VOLTAGES
Single & 3-phase available

Lightweight, quiet and portable, the CM Prostar is designed and built for the unique rigging needs encountered at small venues. Featuring an overload device that protects the hoist, operator and structure from damaging overloads.

KEY FEATURES

DC ELECTRO-MECHANICAL DOUBLE BRAKES

Non-adjusting for low maintenance and quite operation.

GEARING

Precision machined gears heat treated for strength and durability.

CHAIN GUIDE

One piece jam free for smooth operation.

HOUSING

Lightweight, cast aluminum, durable and strong black powder coated finish for low visibility.

LIFT WHEEL

CM patented 10 pocket oblique lift wheel for quiet and smooth operation.

LOW VOLTAGE CONTROL

110 Volt for long cable runs without voltage drop. 24 and 48 Volt optional.

DUTY CYCLE

H-4 duty rated, designed for heavy duty application.

STANDARD FEATURES

OVERLOAD PROTECTION

Helps prevent lifting of dangerous overloads.

CHAIN STOP

Mounted on Load Chain prevents over-travel.

METRIC RATED

LOAD CHAIN

Designed and manufactured by Columbus McKinnon. Zinc plated to protect against corrosion. Black phosphate finish optional.

THE INDUSTRY'S BEST LIFETIME WARRANTY

MEETS OR EXCEEDS WORLD STANDARDS

OPTIONAL FEATURES

CHAIN BAG

Easy-to-Mount Cloth Type Bags.

DOUBLE BRAKE

ENCODER



SPECIFICATIONS PROSTAR

CAPACITY	NUMBER OF CHAINS	MOTOR (HP)	LIFT SPEED (FPM)	WT. LESS LESS CHAIN (LBS)	WEIGHT 1FT OF CHAIN (LBS)	FULL LOAD AMPS	
						1-PHASE	3-PHASE
300	1	1/6	16	28	.35	3.6	.6" / 1.2"
300	1	1/6	16	28	.35		.6" / 1.1"
500	1	1/6	16	28	.35		.7" / 1.2"
500	1	1/6	12	28	.35	4	-
600	2	1/6	8	36	.7	3.6	.6" / 1.1"
600	2	1/6	8	36	.7	3.6	.6" / 1.1"
1000	2	1/6	8	36	.7		.7" / 1.2"

*415 Volt operation †220 Volt operation

MODELS (LBS)	LIFT SPEED (FPM)	OPERATING VOLTAGE			
		SINGLE PHASE		THREE PHASE	
300	16	115-1-50/60	220-1-50/60	220-3-50/60	415-3-50/60
300	24	-	-	220-3-50/60	415-3-50/60
300	40	-	-	220-3-50/60	415-3-50/60
500	12	115-1-50/60	220-1-50/60	-	-
500	16	-	-	220-3-50/60	415-3-50/60
500	20	-	-	220-3-50/60	415-3-50/60
600	8	115-1-50/60	220-1-50/60	-	-
600	12	-	-	220-3-50/60	415-3-50/60
1000	6	115-1-50/60	220-1-50/60	-	-
1000	8	-	-	220-3-50/60	415-3-50/60
1000	12	-	-	220-3-50/60	415-3-50/60

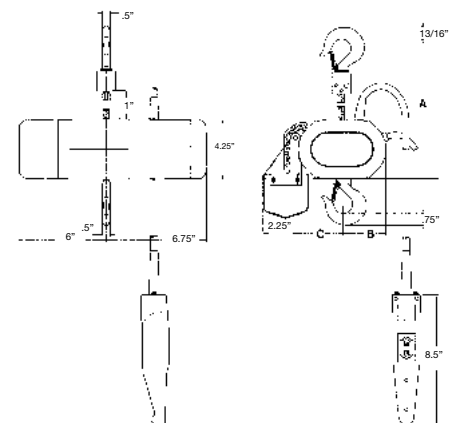

DIMENSIONS

DRAWING LEGEND	REEVING	
	SINGLE	DOUBLE
A	11"	12 1/8"
B	2 15/16"	3 1/2"
C	2 7/8"	2 3/8"

MANUAL HOISTS

Hand Chain & Cable Lever Hoists



HURRICANE 360° HAND CHAIN HOIST

- Capacities: 1/2 to 10 tons
- Standard Load Limiter for simple, automatic overload protection.
- Improved braking system is exceptionally quiet, and improves operational safety and serviceability.
- Powder coated finish for corrosion protection.
- All internal gears and pinions are heat treated steel for high strength and long life.
- Chain Guide and Stripper assures load chain alignment.
- Precision 4-Pocket Liftwheel is fully machined for better chain fit and reduced wear allowing for accurate movement of the load chain.
- Alloy steel load chain assures high strength and long wear life.
- Minimal maintenance, easily dis-assembled, requiring no special tools.
- Metric rated



SERIES 622 HAND CHAIN HOIST

- Capacities: 1000 lbs. to 10 tons
- Simple, efficient, economical design.
- Compact design, low headroom and lightweight steel construction for easy installation, even in confined spaces.
- Weston-type load brake requires no lubrication.
- Hand wheel cover with guide slots minimizes jamming and slipping.
- Forged swivel hooks with latches reduce twisting of chain and unintentional unhooking of load when chain is slack.
- Standard hand chain drop is 2 feet less than lift (example: 8 ft. lift hoist has 6 ft. hand chain drop).
- One-year warranty
- Metric rated



SERIES 653 LEVER OPERATED HOIST

- Capacities: 3/4 to 6 tons
- Hardened steel load sharing gears.
- Double pawl arrangement for assured load control.
- Two chain guide rollers for positive chain engagement.
- Weston type braking system for positive load control and positioning.
- Simple one-handed, free chaining for fast load attachment.
- Hardened steel chain for strength and long wear life.
- Forged upper and lower hooks with heavy cast steel latches.
- 5-year warranty against defects in materials and workmanship.
- Meets ASME B30.21 – Manually Lever Operated Hoist Standard and European CE Standard.
- Metric rated



SERIES 602/603 LEVER OPERATED HOISTS

- Capacities: 500 lbs. & 1000 lbs.
- Plated load chain is standard.
- Weston-type load brake.
- Rubber hand grip for better comfort and security.
- Lightweight design for ease of portability. Use in confined conditions with one-hand operation.
- Forged upper and lower hooks with latches standard.
- Impact resistant, all-steel frame, gear case and cover.
- Hardened link-type alloy steel load chain for strength and long wear.
- Free wheeling feature serves to quickly attach the load.
- Metric rated



CABLE LEVER OPERATED HOIST

- Capacities: 500 lbs. to 2 tons
- Handle design for overload protection – bends to prevent overload.
- Hooks with safety latches – 360° swiveling hooks equipped with safety latches for positive load engagement.
- Lightweight and rugged – special cast aluminum alloy housings.
- Corrosion resistant – all stainless steel springs and shafts.
- Easy load positioning – utilizes a double interlocking pawl system for precise load adjustment.
- Open construction – allows for easy cleaning and inspection.
- Self-storage cable drum – provides compact operation.



GT SERIES GRIP & PULL WIRE ROPE LEVER TOOL

- Capacities: 1 to 3 tons
- Smooth Operation and Low Wear – The large surface area of the clamping jaws provides an evenly distributed grip.
- Unique jaw design prevents damage to the wire rope.
- Limitless Wire Rope Travel – Versatility for use over long distances specially suits this tool for use in the entertainment industry.
- Durability – Lightweight and compact design for portability, yet built tough for long life and trouble free service.
- Overload Protection – Easily replaceable, shear pin design to protect against dangerous overloads.
- Telescopic Handle – Enhances portability and ease of operation.
- Minimal Maintenance – Periodic cleaning, inspection, and lubrication is all that is required.
- Lifetime warranty – Lifetime warranty against defects in materials and workmanship.

TROLLEYS & CLAMPS

Full Complement to our Hoists

PLAIN & GEARED TROLLEYS

- Capacities: Rated loads from 500 lbs. to 5 tons in plain and geared models.
- Economical – Excellent low cost choice for manual and powered hoists.
- Rugged – Designed to provide superior performance and long, efficient service.
- Low Rolling Effort – Geared models have standard 6 ft. hand chain drop. Other hand chain drops available.
- Universal Hanging Clevis – Accepts most hook mounted hoists.
- Adjustable – Trolley easily adjusts to fit any beam flange within range of adjustment, up to an 8.7" flange width.
- Wrap-Around Side Plates – Lugs provide additional security to increase operator safety and act as bumpers to protect wheels.
- Dual Tread Wheels – Will fit either tapered or flat beam flange within range of adjustment. Wheels include permanently lubricated, shielded ball bearings for long life and low maintenance.
- Lifetime Warranty

CM SERIES 632 CLOSE RADIUS TROLLEY

- Capacities: Rated loads from 500 lbs. to 3 tons
- Negotiates radius curves as tight as 7" to 10".
- Made of highest quality rolled steel.
- Unique double row, ball bearing wheel design for greater wear capacity.
- Larger V-bars available for wider flange adjustment.
- For low headroom applications.
- Permanently lubricated bearings.
- Exclusive Dial-Fit collar quickly adapts trolley to wide range of beams and patented rails.
- Dust covers shield and protect bearings.
- Trolleys available for larger beams, rails or tracks.
- Cast iron trolley guards available (except for 3 ton).
- Lifetime Warranty

VTE ELECTRIC MOTOR DRIVEN TROLLEY WITH ENCODER

- Specially designed to be operated with a VFD for use in moving video screens or when variable speed and smooth movement is needed.
- The trolley motor has a worm gear transmission that ensures smooth starting, stopping and self braking.
- The sturdy compact frame has a low overall height and is very easy to install and adjustable to different beam sizes.
- Motor protected to IP55
- Maximum Travel Speed: 70 fpm



CM BEAM CLAMP

- Working load limit up to 10 tons
- Suitable for use with powered hoists and chain blocks.
- Load pin incorporated for load suspension with reduced headroom.
- Designed to fit flanges of most structural beams.
- All CM Screwlok girder clamps are factory proof tested and a certification is shipped with each product.



RIGGING

STAC Chain, Shackles & Accessories



CM SCREW PIN ANCHOR SHACKLES

- Work Load Limits: 1/2 to 43 tons
- Size Diameter: 3/16" to 2"
- Surface Finish – Self colored, painted or galvanized per ASTM.
- Strength and Abrasion Features – All shackle bodies and pins are forged from special steel, heat treated and tempered to give greater strength and abrasion resistance.
- Positive and Easy I.D. – All shackles are marked with size (mm and in.) and working load limit in tons.
- Strength Plus – Ultimate strength equals 5 times working load limit. Proof load equals 2.2 times working load limit.
- CE Marked

THEATRICAL SHACKLES - BLACK DIMENSIONS (INCHES)



WORKING LOAD LIMIT (TONS)	D	P	W	L	B	R
3	1/2"	5/8"	13/16"	1 15/16"	1 3/8"	1 3/8"
4 1/2	5/8"	3/4"	1 1/16"	2 3/8"	1 5/8"	1 5/8"
6 1/2	3/4"	7/8"	1 1/4"	2 7/8"	1 3/4"	2 1/8"

Screw pin standard, round pin and bolt and nut type also available.
100% Proof tested at 2.2 times the working load limit.
Ultimate strength equals 6 times the working load limit

ANCHOR SHACKLES, SCREW PIN - CARBON STEEL DIMENSIONS (INCHES)

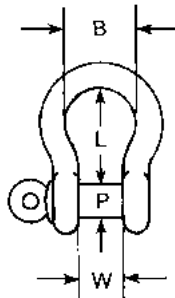
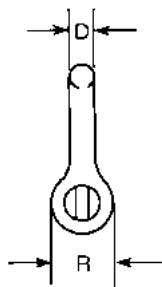

WORKING LOAD LIMIT (TONS)	D	P	W	L	B	R
3	1/2"	5/8"	13/16"	1 15/16"	1 3/8"	1 3/8"
4 1/2	5/8"	3/4"	1 1/16"	2 3/8"	1 5/8"	1 5/8"
6 1/2	3/4"	7/8"	1 1/4"	2 7/8"	1 3/4"	2 1/8"

Available in diameters from 3/16" to 2". Available unpainted, black, or galvanized.

ANCHOR SHACKLES, SCREW PIN - ALLOY STEEL DIMENSIONS (INCHES)



WORKING LOAD LIMIT (TONS)	D	P	W	L	B	R
3 1/3	1/2"	5/8"	13/16"	1 15/16"	1 3/8"	1 3/8"
5	5/8"	3/4"	1 1/16"	2 3/8"	1 5/8"	1 5/8"
7	3/4"	7/8"	1 1/4"	2 7/8"	1 3/4"	2 1/8"

Available in diameters from 3/16" to 2". Available unpainted, black, or galvanized.

THE CM SPECIAL THEATRICAL ALLOY CHAIN (STAC)

Ideal for theatrical rigging applications where bridle adjustability is required.

SUPER STRENGTH

Grade 80 alloy material with 1/2" diameter and 6 ton working load limit

HEAT TREATED

Alloy steel provides long life

MEETS EUROPEAN STANDARDS FOR LONG LINK CHAIN

PROOF TESTED

Each link proof tested to assure weld and material integrity

FIRE & ABRASION RESISTANT

4:1 DESIGN FACTOR

POSITIVE AND EASY ID

Chain embossed with "STAC 8" and "CM USA" for easy identification as CM alloy. Also tagged with size, grade, reach and working load limit.

VERSATILITY

Link accepts up to 3/4" shackle for adjustability

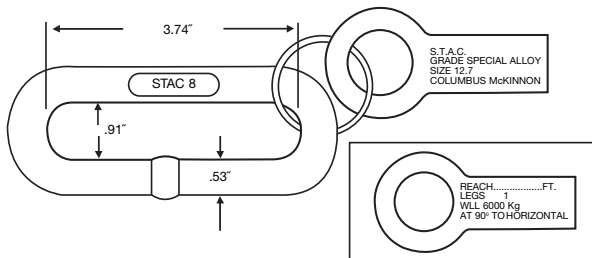

WIRE ROPE CLIPS

Wire rope clips are used to secure the end of wire rope when forming a loop, i.e., for wire rope turn back. Available in mid-grip (double saddle) and single saddle.

Mid-grip clips are available in a drop forged carbon steel material and single saddle clips are available in malleable iron or drop forged carbon steel. Available in sizes up to 1 1/2".



LAP LINKS

A quick permanent way to repair general purpose chains. Chain link and attachments are threaded onto the lap link and the link flattened. Available in a variety of sizes with stock diameters from 1/8" thru 5/8" chain. **Not to be used for overhead lifting and prohibited for all load securement applications by CVSA.**



QUICK LINKS

Afford quick and easy chain repair and/or attachment of fittings. Easy closing by threading nut onto threaded end. Reusable. Available in stock diameters ranging from 1/8" to 1/2". **Not to be used for overhead lifting, and prohibited for all load securement applications by CVSA.**



SHOULDER EYE BOLTS

- Forged steel/quenched and tempered.
- Metric sizes available.
- Recommended for straight line pull.



GRADE 100 CHAIN

- Working load limit up to 17 tons.
- Diameter sizes available from (7/32" to 3/4").
- Meets or exceeds many National and International standards.
- 25% higher working load limit when compared to Grade 80.
- Available self-colored, or grey thermal dip.
- Certification included with every drum.
- 100% proof tested.



THIMBLES-WIRE ROPE

Made specifically for wire rope turn back forming a cable loop. Used in conjunction with wire rope clips. Manufactured of hot rolled steel in accordance with FED. SPEC. FF-T-276. Available in sizes to fit a maximum of 1 1/2" diameter wire rope.



TURNBUCKLES

Turnbuckles find many uses to apply tension to wire rope or cable. They are composed of a forged body and two end fittings. End fittings can be eyes, jaws, or hooks. They must, however, be applied only up to loads within their working load limit as specified for the particular end fitting being applied.



EYE SWIVELS

- Hot dip galvanized.
- Ultimate load is 5 times working load limit.
- Meets the performance requirements of RR-C-271D, Type VII, Class 2.
- Made in USA
- Regular forged eye and eye swivels.



GRADE 30 CHAIN

- An economical utility chain for apps which do not require a high strength to weight ratio.
- Typically used as trim chain or studio chain.
 - Low carbon steel.
 - Diameter sizes available from 3/16" to 1"
 - Available as self colored, zinc plated, or hot galvanized.
 - Also available in Grades 43, 70, 80 and 100



360° CHAIN RIGGING SYSTEM

Capacities up to 5 tons

Ideal for the exhibition and events industry, the 360° Chain Rigging System constitutes a groundbreaking innovation allowing to significantly reduce set-up times and production costs – and in some cases, eliminate the need for complex pre-rig systems.

The 360° System is uniquely suited for new construction projects or acting as a supplement to permanent rigging installations; and will work with a variety of ceiling and supporting structure material such as steel or concrete.

Approved by German and European Standards (f. i. TÜV-certificate), Material: S355 (ST 52),
USA Patent: US2009/0159773,
German Patent: DE 10 2007 061 349

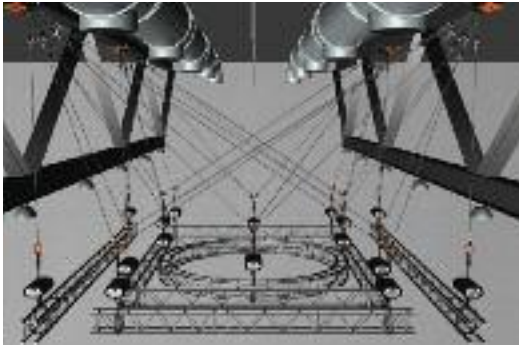
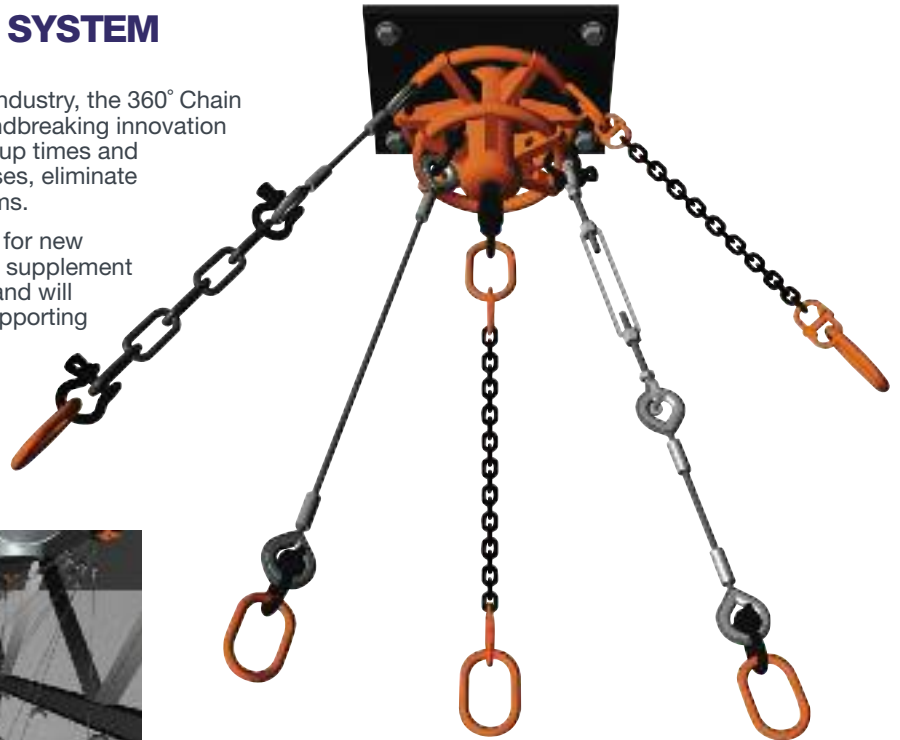

CM RIGGING GUIDE

From determining proper chain sling angles and rigging capacities to calculating tensions and choke reductions, this handy pocket guide is packed full of valuable information for the rigging professional. You'll keep yourself and co-workers safe with current requirements, unit conversion charts, and much more at your fingertips.



CABLE REELS

CM Cable Reels give you more for your money. They are ruggedly built and their design has been refined over many years of field use. The reels have either fully automatic or ratchet controlled spring rewind and contain all the features found in any reel in this size range. Sliprings can also be supplied for DMX, Cat 5 and Speakon applications.



LINEAR ACTUATORS & SCREW JACKS

Linear Actuators are utilized in the design, manufacturing and installation of stage equipment in theatres, schools, community centers, special effects in live shows and movies. The carrying capacities are between 1 ton and 25 tons with average lifting speeds of 120 inches per minute. Self-locking screw are designed for lowering podiums, shifting floors, and raising and lowering stages. The carrying capacities are between 10 tons and 50 tons, with average lift speeds of 54 inches per minute.



WIRE ROPE GRIPS

- Capacities: 1,000 to 20,000 lbs.
- Securely holds wire in place while pulling or stretching.
- Versatility – All models are rated for a variety of wire sizes and types, so fewer grip changes are required.
- Grips open easily and release instantly to quickly insert or remove wire.
- Large handle eye opening accepts standard hooks and easily attaches to tackle blocks.
- Standard or Aggressive Jaw models available.
- Rugged and Portable – Forged steel construction is durable yet lightweight.
- Yellow chromate finish protects components from rust and corrosion.



WINCHES

Electric & Hand Wire Rope Winches

CM offers a diverse range of electric and hand wire rope winches for lifting, lowering, pulling and positioning loads to meet your specific needs.

Wall-mounted hand wire rope winches are ideal for the raising and lowering of banners, nets, and scenery. Additionally, console-mounted wire rope winches provide maximum flexibility when used in theatres and studios. Electric wire rope winches provide superior performance when lifting speeds are vital. Whatever the lifting requirement, there is a Meteor winch for the job.



SW-E STANDARD ELECTRIC WIRE ROPE WINCH

- Capacities: up to 8.25 tons
- Rope Speeds: up to 98.4 feet/minute
- The aluminum compact wire rope winch has a closed construction and therefore requires little maintenance.
- Perfect for superstructures on vehicles & trailers and when lifting & lowering a wide variety of loads.
- Overload protection available.
- Multiple line winches available.
- C1 compliance available.



MODEL RPE ELECTRIC WIRE ROPE WINCH

- Compact dimensions due to internal brake motor.
- Adjustable slip clutch to protect the winch from overloading standard for Model RPE 10-6.
- Spur gear transmission with helical first gear ensures smooth motion. Lubricated by grease and can, therefore, be used in any position.
- Plain rope drum standard. Grooved drum available.
- Spring pressure disc brake incorporated in the motor holds the load secure even in the event of a power failure.
- The rope is secured to the drum in a recess so that the rope can be wound onto the drum in several layers without damage.
- The standard version comes with Low Voltage Control. Direct Control optional.
- Integrated emergency stop.



SW-K-LB WIRE ROPE WINCH

GALVANIZED DESIGN
Capacities: 330 to 2,645 lbs.

We have designed manual lifting to be not only secure but also ergonomic: The friction disk brake equipped with a shuttle valve on our wire rope winch prevents unintentional lowering of the load in every position. These wire rope winches have been galvanized for maximum protection against corrosion.

SW-K-LB-VA WIRE ROPE WINCH

STAINLESS STEEL DESIGN
Capacities: 550 to 1,985 lbs.

The robust high-quality LB wire rope winch is made of V2A stainless steel – suitable for outside use.

Whether used for lifting, opening gates, or for lifting & lowering portable staging, this console-mounted hand wire rope winch effortlessly handles the job.

WINCHES

Electric & Hand Wire Rope Winches



SW-W WALL-MOUNTED WIRE ROPE WINCH

Capacities: 176 to 2,204 lbs.

With a removable crank, inside braked spring retention, and aluminum housing, workers in gymnasiums, auditoriums, aquatic centers and arenas will find the SW-W winch the perfect equipment for most requirements.

The versatile SW-W, equipped with a toothed spur wheel back gear, has a low net weight and compact design which allows it to meet an abundance of requirements. Easily mounts onto the wall and permits rope output in any direction.



SW-W-SGO WALL-MOUNTED WIRE ROPE WINCH WITH WORM GEAR

For the lifting and lowering of a wide range of loads, our manual wire rope winch with worm gear and additional friction disk brake is mounted onto the wall and takes up to 5 tonnes tension loads. Winch housing and rope drum are made of sturdy steel plate. Sizes from 2 tonnes upwards are equipped with an additional speed increasing ratio used for overdrive.

OPTIONS: Multi-compartment, Zinc plated, Grooved drum



DSR SHEAVES

The steel DSR sheaves feature a wear-resistant rope guide where the machine groove is perfectly adjusted to the wire rope. Fifteen different types guarantee a made-to-specification solution at loads of up to 8 tons. The sheaves can be varied in wire and sheave diameter (from 3.125" up to 19.3125") – and as standard all sheaves are equipped with ball bearings. The sheaves are one of the guiding elements within the comprehensive CM product range of wire rope winches, wire rope and wire rope pulley blocks.

TRAINING

Be Safe. Get Trained.

For decades, the Lodestar Electric Chain Hoist or "Motor" has taken on many different supporting roles in the entertainment industry. From standard lifts to sophisticated computer-automated projects, the Lodestar has been the number one choice in the market. Loyal users trust the Lodestar for unparalleled reliability and durability, show after show.

As the entertainment industry continues to evolve through technological advancements and greater production demands, the need for qualified and trained hoist technicians continues to expand.

From basic motor maintenance training to certification classes, professionals from Columbus McKinnon cover everything from hoist design and operation to maintenance tips of the trade. Participants become well versed in all aspects of hoist technology and understand practices related to safe operation and long hoist life.

Columbus McKinnon offers classes covering many areas of entertainment technology industry including:

- Basic Lodestar Introduction & Maintenance
- Road Hoist Technician Certification
- Entertainment Rigging
- Truss Safety & Standards
- Rigging Hoist Technician Certification
- Motor Technician Certification

For course information and schedules, please visit www.cmcodepot.com or call 1-877-298-6511





**COLUMBUS MCKINNON CORPORATION
ENTERTAINMENT PRODUCTS**

140 John James Audubon Parkway, Amherst, New York 14228
USA 800.888.0985 | +1 716.689.5400 | Fax +1 716.689.5644 | www.cm-et.com



©2014 Columbus McKinnon Corporation. All Rights Reserved.

Stock # CMETPC-0614 EP 1000 BB